

JIER S2-PROGRESSIVE PRESS

400/600 Metric Ton Presses

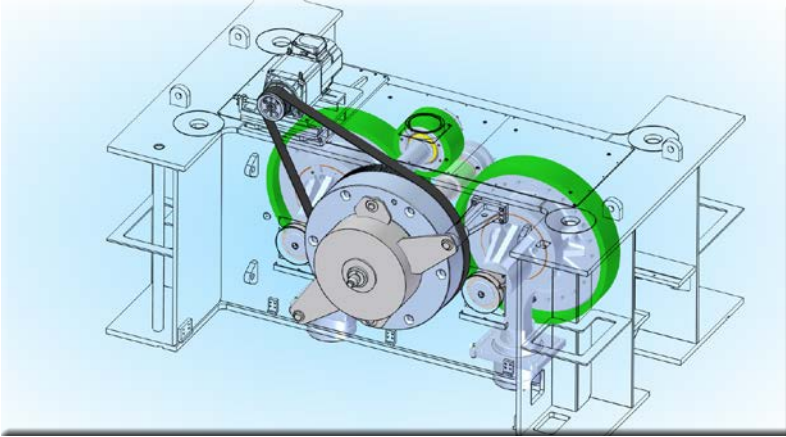

- Eccentric Design
- Heavy Duty
- High rigidity



JIER S2-PROGRESSIVE PRESS

400/600 Metric Ton Presses

Eccentric Gear / Heavy Duty / High rigidity

Specification		S2-400	S2-600
Capacity	kN	4,000	6,000
Nominal stroke above BDC	mm	13	13
Slide stroke	mm	300	500
Continuous Speed	SPM	25 - 60	15 - 45
Die Size	mm	3,050 x 1,530	3,650 x 1,525
Shut height	mm	720	900
Slide adjustment	mm	250	300
Adjustment speed	mm/min	50	50
Thickness of slide plate	mm	110	130
Max weight of upper die	kg	5,000	5,000
Max weight of die	kg	10,000	10,000
Bolster size (LR x FR)	mm	3,050 x 1,530	3,650 x 1,525
Bolster height above floor	mm	1,350	1,350
Thickness of bolster	mm	200	230
Side opening size (Width x Height)	mm	1,220 x 780	1,320 x 915
Height of press,appr	mm	6,700	8,100
Main motor power	kW	50	74
Press Weight,not incl.sound enclosure	Kg	81,000	130,000

S2-400 IS AVAILABLE FOR SHIPMENT



JIER North America Inc.

14975 Cleat Street, Plymouth, MI 48170

Office: 734.404.6683, E-mail: sales@jier-na.com

www.jier-na.com